

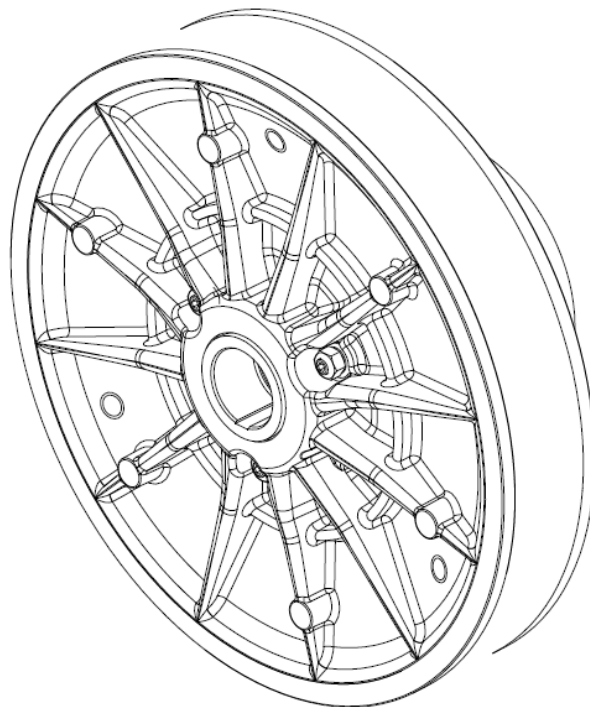

# INSTALLATION AND MAINTENANCE GUIDE FOR A CONTINUOUSLY VARIABLE DRIVEN PULLEY (60)



[www.cvtech-ibc.com](http://www.cvtech-ibc.com)

CVTech-IBC inc.  
300, rue Labonté,  
Drummondville (Québec)  
Canada J2C 6X9

Document : 6046-5001-EN-rev2

April 2023

# TABLE OF CONTENTS

<b>IMPORTANT NOTICE</b>	<b>3</b>
<b>MAINTENANCE FREQUENCY</b>	<b>4</b>
<b>NECESSARY HANDLING TOOLS</b>	<b>5</b>
<b>PULLEY INSTALLATION AND TIGHTENING ON THE VEHICLE</b>	<b>6</b>
<b>PULLEY GEOMETRICAL SPECIFICATIONS</b>	<b>7</b>
<b>PULLEY REMOVAL FROM THE VEHICLE</b>	<b>8</b>
<b>DRIVE BELT INSPECTION</b>	<b>9</b>
<b>PULLEY DISASSEMBLY</b>	<b>10-11-12-13</b>
<b>SLIDING FLANGE MAINTENANCE</b>	<b>14</b>
<b>PULLEY RE-ASSEMBLY</b>	<b>15</b>

# IMPORTANT NOTICE

Only qualified personnel should perform maintenance and repair operations on this continuously variable pulley.



Means there is a risk of serious injuries if the instructions are not followed as described.



Means that, when performing this step, there is a risk of damaging a part or may cause components malfunction.

**CVTech shall not be liable for any damage or injury resulting from misunderstanding of the text**, improper use of the transmission system, or improper use of the recommended tools.

It is very important to always use the indicated tightening torque.

# MAINTENANCE FREQUENCY



This continuously variable pulley does not require any lubrication. It is designed to work without any lubricant. Given this, certain rules of cleanliness must be applied when handling the system to avoid having any lubricants come into contact with its components.



To increase the life of the continuously variable pulley, it is strongly recommended that you respect the following recommendations:

- Perform maintenance according to the table below
- Replace the worn parts. This ensures correct operation and will prevent any warranty from being excluded from the continuously variable pulley.

Description	Maintenance interval	
	Every 5 000 Km or 250 h	Every 10 000 Km or 500 h
<b>Driven pulley</b>	Visual inspection	Disassemble and Clean
Fixed sheave	Visual inspection	Clean
Sliding sheave	Visual inspection	Clean
Cam	Visual inspection	Clean
Cam shoes	Dimension / Visual	Replacement recommended
<b>Drive belt</b>	Dimension / Visual	Dimension / Visual

# NECESSARY HANDLING TOOLS

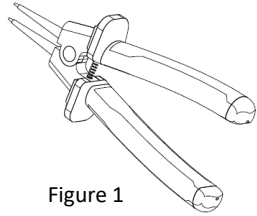

Figure 1  
*Snap ring pliers*

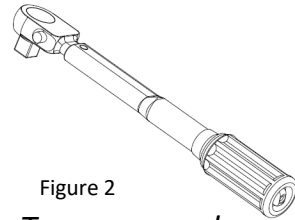

Figure 2  
*Torque wrench*

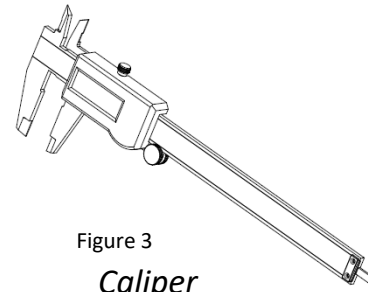

Figure 3  
*Caliper*

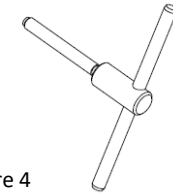

Figure 4  
*\*Flange spreader*

*Refer to owner's manual  
for part number*

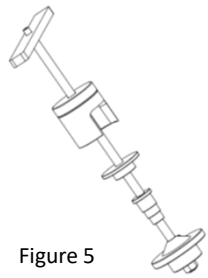

Figure 5  
*\*Pulley disassembly tool  
(5055-0002)*

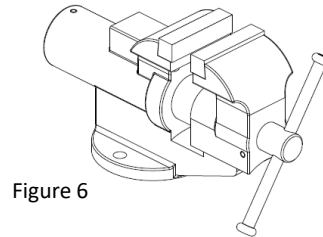

Figure 6  
*Vise*



Figure 7  
*\* Alignment tool*  
*Refer to owner's manual  
for part number*

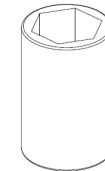

Figure 8  
*Appropriate sockets for  
removing pulley fixation  
bolt*

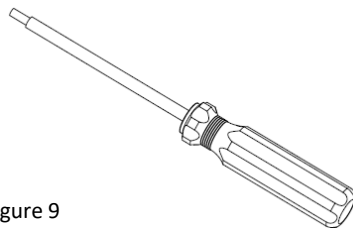

Figure 9  
*No. 20 Torx screwdriver*

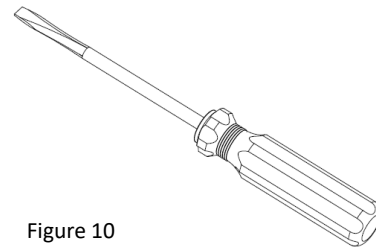

Figure 10  
*Flat head screwdriver*

*\* Tool available from CVTech*



***Important: Using impact tools  
is not recommended.***

# PULLEY INSTALLATION AND TIGHTENING ON THE VEHICLE

## Driven pulley installation

- Assemble the driven pulley onto the gearbox shaft.

## Recommended torque: Refer to owner's manual

- To tighten the driven pulley, engage the transmission on a gear and prevent the vehicle from moving using the vehicle brakes.



Do not forget to remove the tools from the driven pulley once the installation is completed.



Before you start the engine :

- Make sure all the components are clean, without any trace of oil, dust and contaminant.
- Do not use any lubricant.

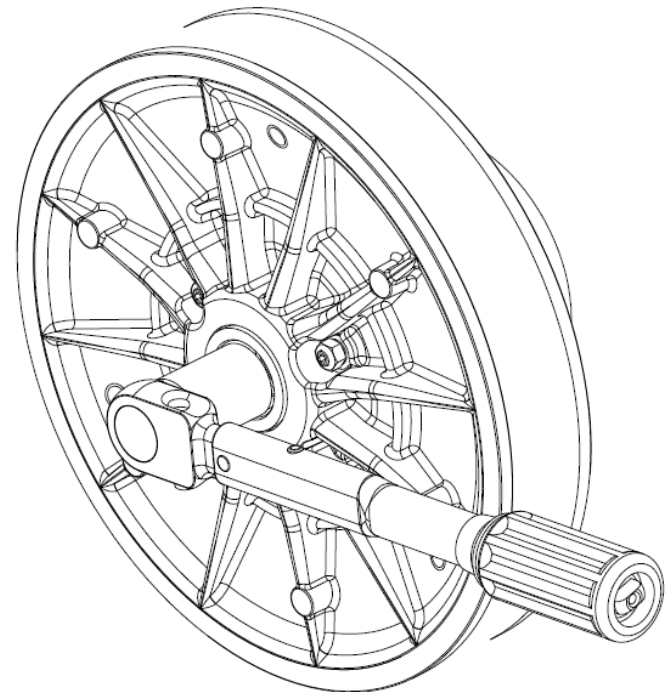

Figure 11

# PULLEYS GEOMETRICAL SPECIFICATIONS

## Alignment between pulleys

- After completing the installation, check the alignment between the pulleys with the alignment tool. Make sure to obtain dimension A (figure 12) and the proper alignment tool part number (refer to owner's manual for both).
- If dimension A is out of tolerance, you can add or remove shims from the gearbox shaft to help reach it.

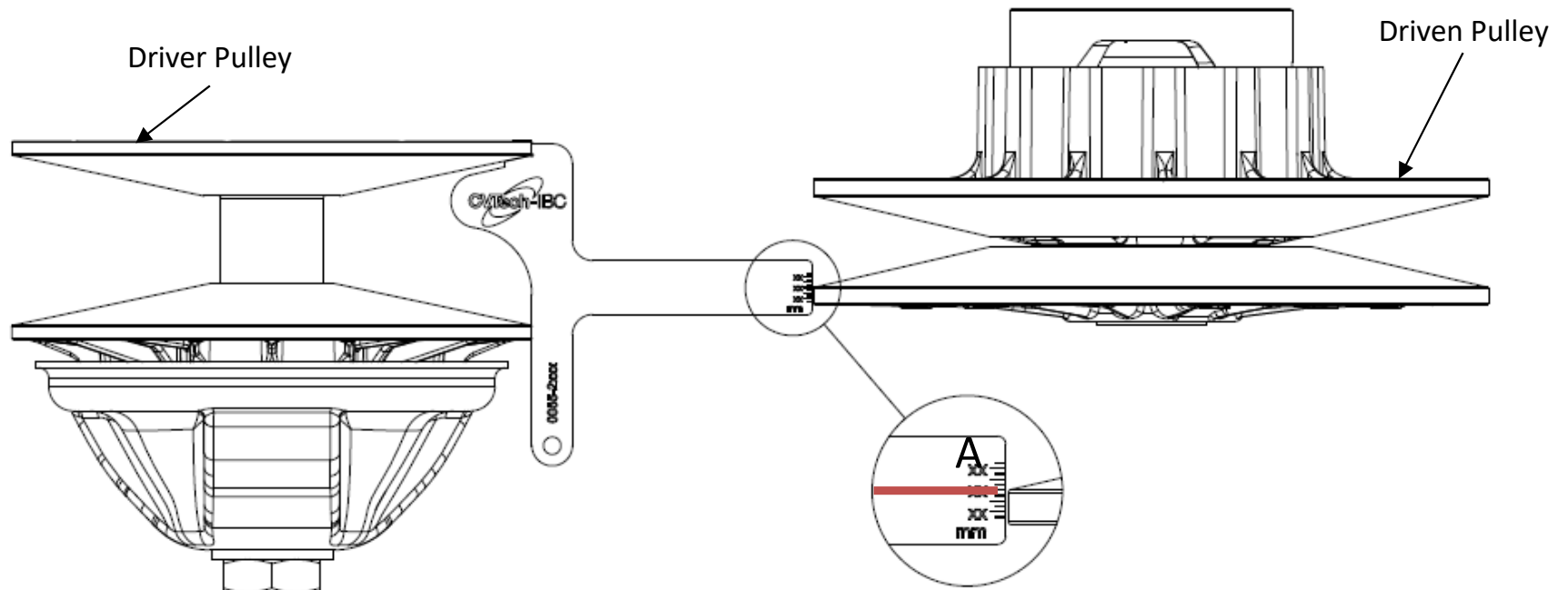

Figure 12



The driver pulley is shown for illustration purposes only

# PULLEY REMOVAL FROM THE VEHICLE

## **Removing the driven pulley:**

- If the drive belt is installed, screw the flange spreader "A" in the threaded holes, as shown in figure 13, to remove the drive belt.
- Lock the pulley rotation by engaging in gear and apply the vehicle brakes.
- Remove the bolt or nut from the driven pulley.

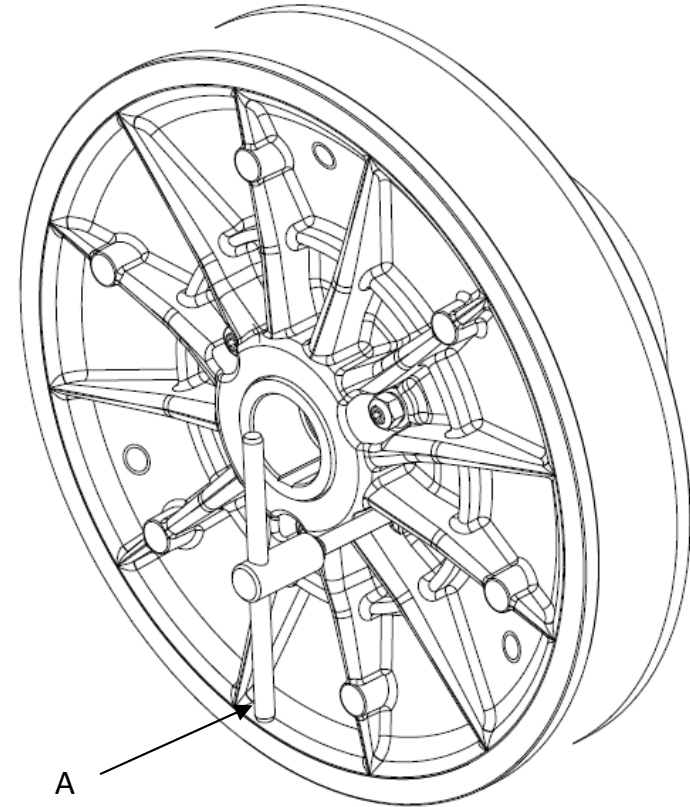

Figure 13



Before disassembling the CVT belt, identify drive belt rotation direction so that it will be the same when reassembling.



# DRIVE BELT INSPECTION



The drive belt must be inspected in order to avoid risk of personal injury and/or material damage.

- The drive belt must be replaced if cracks are seen when turning it inside out.

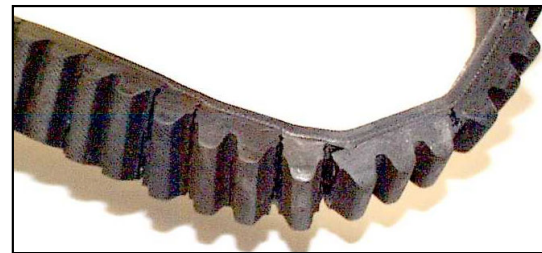

Figure 14

- The drive belt must be replaced when the width at the cord level is approximately 2 mm less than it is on a new belt (refer to owner's manual).
- Make sure to take the measurement at the cord level of the belt.

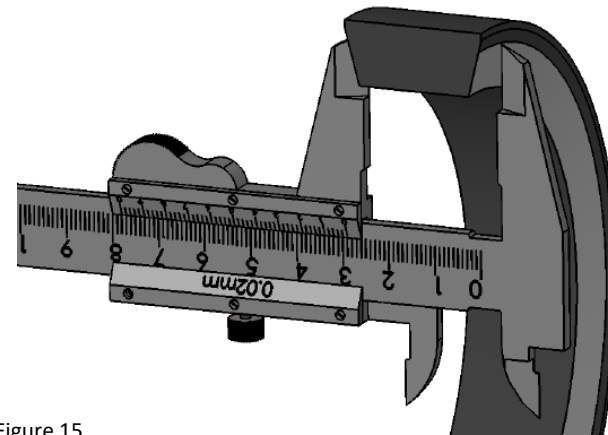

Figure 15

# PULLEY DISASSEMBLY

- 1 Fixed sheave
- 2 Washer (if applicable)
- 3 Sliding sheave
- 4 Cam Shoe
- 5 Cam shoe screw
- 6 Spring
- 7 Cam
- 8 Key
- 9 External retaining ring
- 10 Washer (if applicable)
- 11 Screw (if applicable)
- 12 Nut (if applicable)

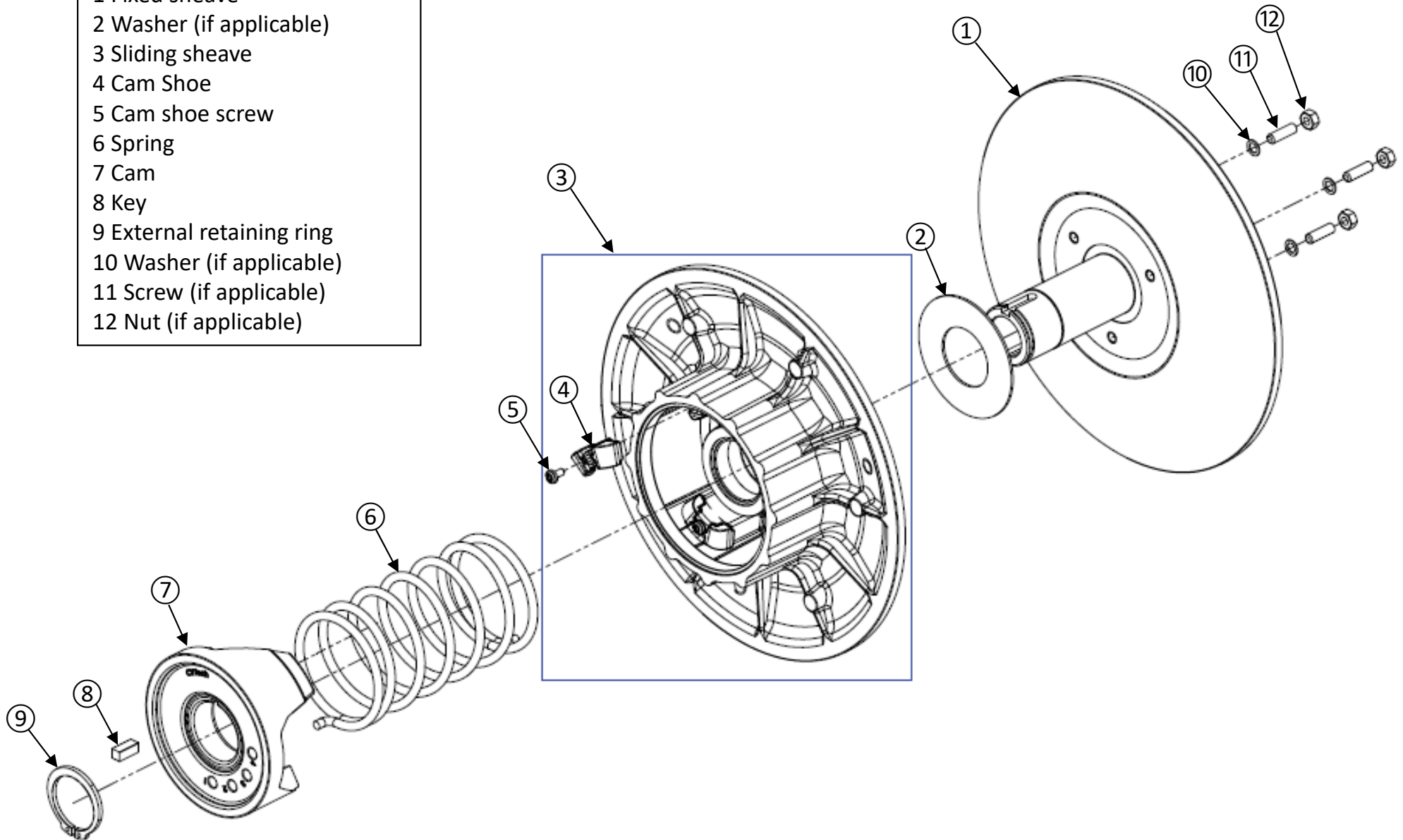

Figure 16

# PULLEY DISASSEMBLY



Make sure you take note of the position of the spring ⑥ lugs in the sliding sheave ③ and cam ⑦ holes, as well as the alignment of the cam ⑦ versus the cam shoe support. When re-assembling the pulley, the positions must be the same as before disassembly. This ensures that pulley performance is not affected.



Use the disassembly tool (see figure 18, next page) to disassemble the cam ⑦. The pulley is spring loaded with significant amount of force, the use of the disassembly tool will keep the pulley compressed.

Suggestion: on the pulley, mark the alignment between the cam and the sliding flange with a colored line.

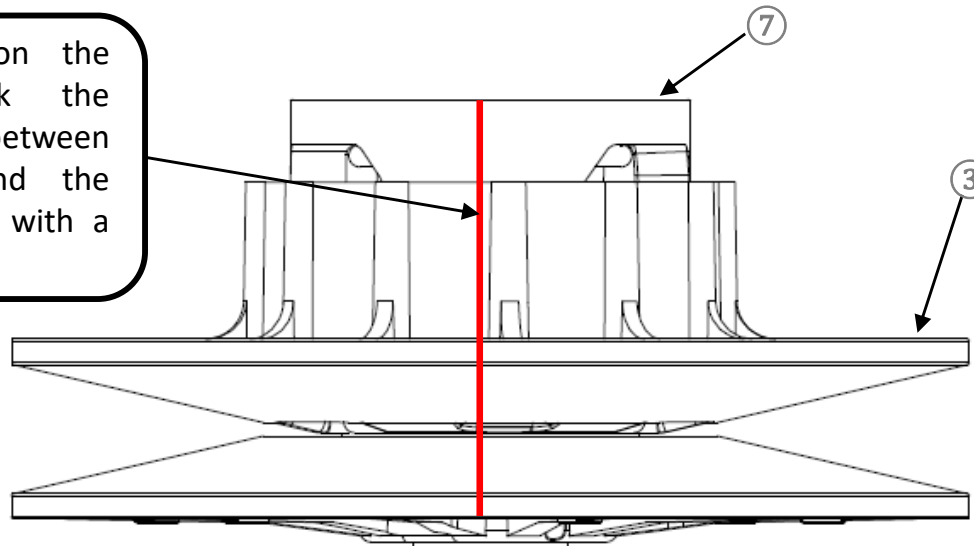



Figure 17

# PULLEY DISASSEMBLY

## Cam ⑦ disassembly

- Using a vise, mount the disassembly tool as shown in figure 18.
- Install the pulley on the disassembly tool as shown in figure 19. Use the lock screw to prevent the rotation of the pulley on the disassembly tool.
- By screwing the bar on the threaded rod, press down cam ⑦ (3 to 4 mm max.) in order to free up the retaining ring ⑨.
- Remove the retaining ring ⑨ using the snap ring pliers (figure 20).
- Slowly unscrew the bar on the threaded rod to release the spring ⑥ tension (figure 21).

 Slowly lift the cam ⑦ to free it from the shaft by unscrewing the disassembly tool once the retaining ring ⑨ is removed.

 Never remove the bar from the disassembly tool until the cam ⑦ is in a free state (Figure 21).

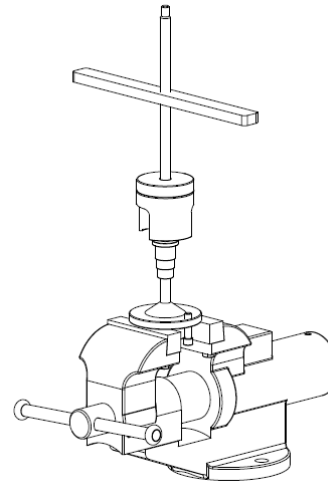

Figure 18

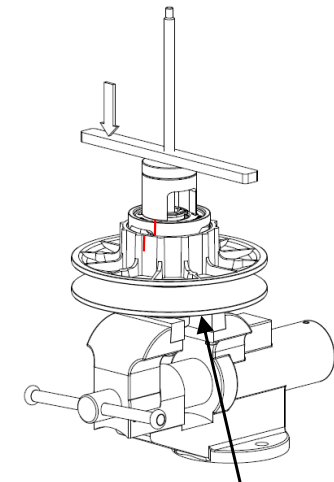

Figure 19

Block rotation

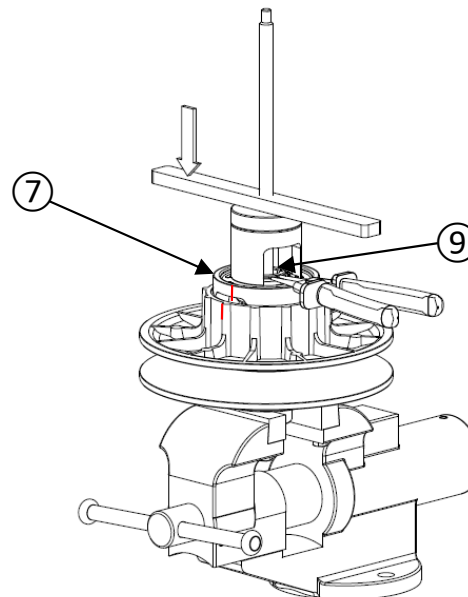

Figure 20

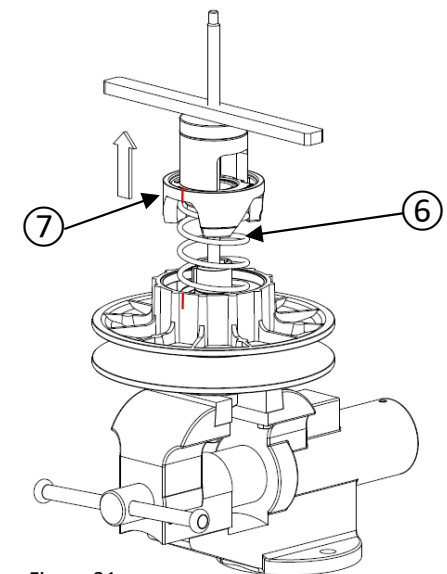
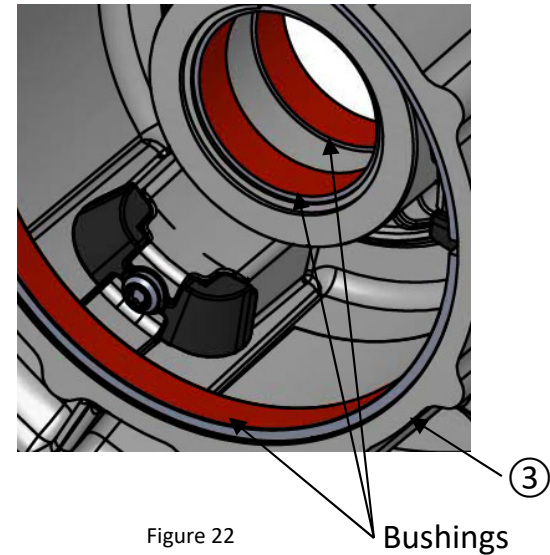

Figure 21

# PULLEY DISASSEMBLY

## Recommended inspection

- Check for wear marks on the cam ⑦.
- Check for wear marks on the spring ⑥.
- Perform a visual inspection of the components.
- Check the wear of the sliding sheave ③ bushings (visual inspection only, figure 22). If there is excessive wear, you must replace the whole sheave assembly ③.



The bushings cannot be removed from the sliding sheave ③ (figure 22).



The shaft cannot be disassembled from the fixed sheave ① (figure 23).



To maintain the performance of the pulley, make sure the sheave bushings are cleaned with a microfiber towel or dry cloth. **CAUTION:** Do not use acetone to clean bushing and do not use any lubricant.

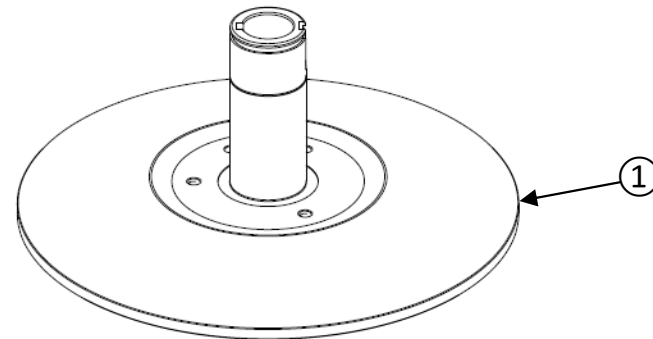

# SLIDING FLANGE MAINTENANCE

## Recommended inspection

- If the cam shoes ④ are worn down to about 1 mm before making contact with the cam shoe support, they must be replaced (figure 24).

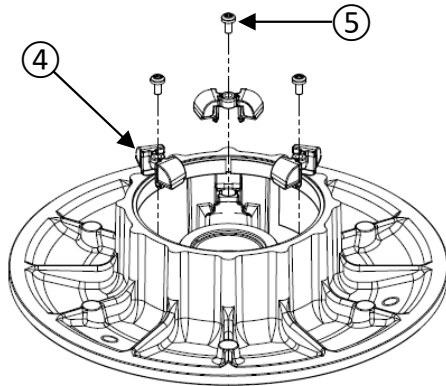

Figure 25

After removing the cam shoe screws ⑤ with a No. 20 torx screwdriver, the cam shoes ④ may be removed using a flathead screwdriver.

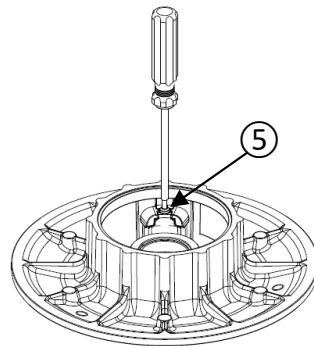

Figure 27

Tighten the cam shoe screws ⑤ using a No. 20 torx screwdriver, at a value of 3,5 Nm

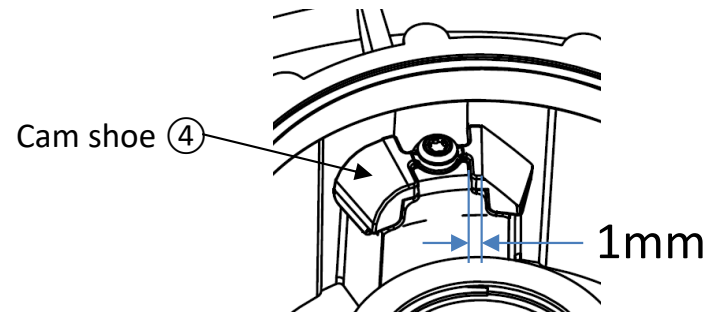

Figure 24

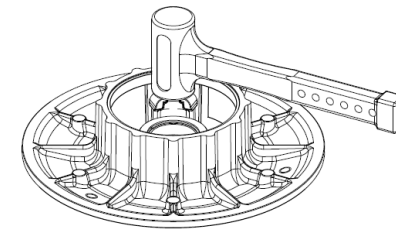



Figure 26

Mount the new cam shoes ④ using a hammer.

 Gently hit the new cam shoes ④ in order not to damage them.

 Always change all 3 cam shoes ④ at the same time.

# PULLEY RE-ASSEMBLY



The use of the disassembly tool is required in order to re-assemble the pulley.

## Pulley re-assembly

- Install the fixed sheave ① on the disassembly tool (figure 28).
- Put the washer ② (if applicable) on the fixed sheave ① then put the sliding sheave ③ (figure 29).
- Place the spring ⑥ lugs into the proper cam ⑦ hole and the proper sliding sheave ③ hole at the same positions noted during the disassembly steps (figure 30).
- Press down the cam ⑦ onto the fixed sheave ① shaft with the disassembly tool. Position the key ⑧ into the fixed sheave ① shaft groove (figure 31 and 32).
- Put the retaining ring ⑨ on the cam ⑦.
- Make sure that the fixed sheave ① is blocked in rotation, turn the sliding sheave ③ counter clockwise or clockwise to position the cam shoe ④ on the proper side of the cam sliding surface as it was before disassembly.
- Screw the disassembly tool bar until the cam ⑦ is low enough to install the external retaining ring ⑨.

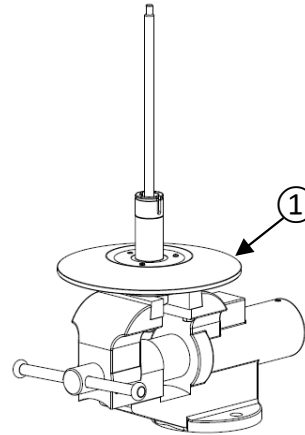

Figure 28

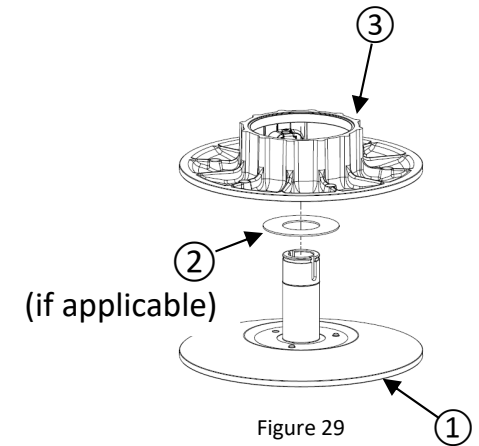

Figure 29

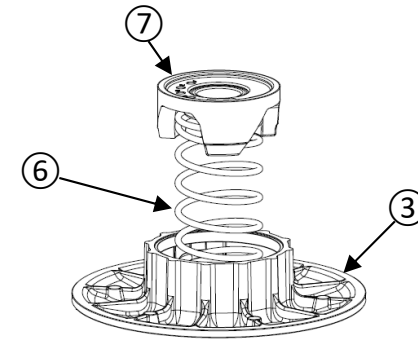

Figure 30

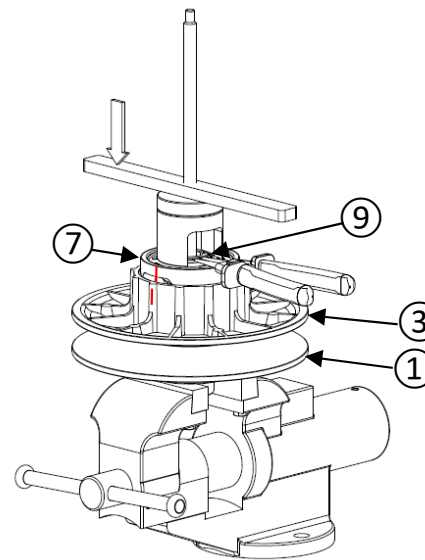

Figure 31

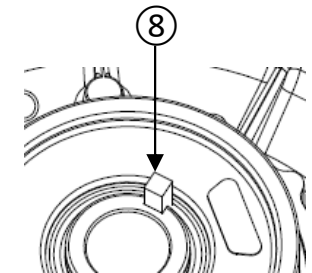

Figure 32